

Surname	Centre Number	Candidate Number
Other Names		0



New GCSE

4463/01

**SCIENCE A
FOUNDATION TIER
PHYSICS 1**

P.M. FRIDAY, 15 June 2012

1 hour

For Examiner's use only		
Question	Maximum Mark	Mark Awarded
1.	9	
2.	6	
3.	5	
4.	7	
5.	6	
6.	12	
7.	6	
8.	9	
Total	60	

ADDITIONAL MATERIALS

In addition to this paper you may require a calculator.

INSTRUCTIONS TO CANDIDATES

Use black ink or black ball-point pen.

Write your name, centre number and candidate number in the spaces at the top of this page.

Answer **all** questions.

Write your answers in the spaces provided in this booklet.

INFORMATION FOR CANDIDATES

The number of marks is given in brackets at the end of each question or part-question.

You are reminded of the necessity for good English and orderly presentation in your answers.

A list of equations is printed on pages 2 and 3. In calculations you should show all your working.

You are reminded that assessment will take into account the quality of written communication (QWC) used in your answer to question 8(a).

Equations and Units

Physics 1

$$\text{power} = \frac{\text{energy transfer}}{\text{time}}$$

$$P = \frac{E}{t}$$

$$\text{units used (kWh)} = \text{power (kW)} \times \text{time (h)}$$

$$\text{cost} = \text{units used} \times \text{cost per unit}$$

$$\% \text{ efficiency} = \frac{\text{useful energy [or power] transfer}}{\text{total energy [or power] input}} \times 100$$

$$\text{density} = \frac{\text{mass}}{\text{volume}}$$

$$\rho = \frac{m}{V}$$

$$\text{wave speed} = \text{wavelength} \times \text{frequency}$$

$$v = \lambda f$$

$$\text{speed} = \frac{\text{distance}}{\text{time}}$$

Physics 2

$$\text{power} = \text{voltage} \times \text{current}$$

$$P = VI$$

$$\text{current} = \frac{\text{voltage}}{\text{resistance}}$$

$$I = \frac{V}{R}$$

$$\text{acceleration [or deceleration]} = \frac{\text{change in velocity}}{\text{time}}$$

$$a = \frac{\Delta v}{t}$$

$$\text{acceleration} = \text{gradient of a velocity-time graph}$$

$$\text{momentum} = \text{mass} \times \text{velocity}$$

$$p = mv$$

$$\text{resultant force} = \text{mass} \times \text{acceleration}$$

$$F = ma$$

$$\text{force} = \frac{\text{change in momentum}}{\text{time}}$$

$$F = \frac{\Delta p}{t}$$

$$\text{work} = \text{force} \times \text{distance}$$

$$W = Fd$$

Physics 3

$$\text{pressure} = \frac{\text{force}}{\text{area}}$$

$$p = \frac{F}{A}$$

$$v = u + at \quad \text{where} \quad \begin{array}{l} u = \text{initial velocity} \\ v = \text{final velocity} \\ a = \text{acceleration} \\ t = \text{time} \\ x = \text{displacement} \end{array}$$

$$x = \frac{1}{2}(u + v)t$$

Units

$$1 \text{ kWh} = 3.6 \text{ MJ}$$

$$T / \text{K} = \theta / ^\circ\text{C} + 273$$

SI multipliers

Prefix	Multiplier
p	10^{-12}
n	10^{-9}
μ	10^{-6}
m	10^{-3}

Prefix	Multiplier
k	10^3
M	10^6
G	10^9
T	10^{12}

Answer **all** questions.

1. The diagram shows how electricity is distributed from a power station to consumers.

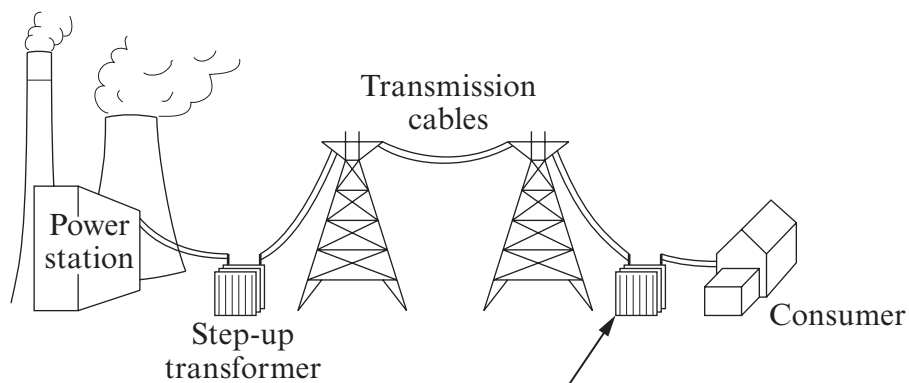

.....

- (a) (i) Fill in the missing label on the diagram. [1]
- (ii) Place a tick (✓) in the boxes next to the **three** correct statements about the step-up transformer. [3]

It allows the electricity to travel further.

It increases the voltage.

It increases the speed of the electricity through the cables.

It decreases the current.

It reduces energy losses from the cables.

It decreases the voltage.

(b) The Sankey diagram shows the energy transfers for this power station.

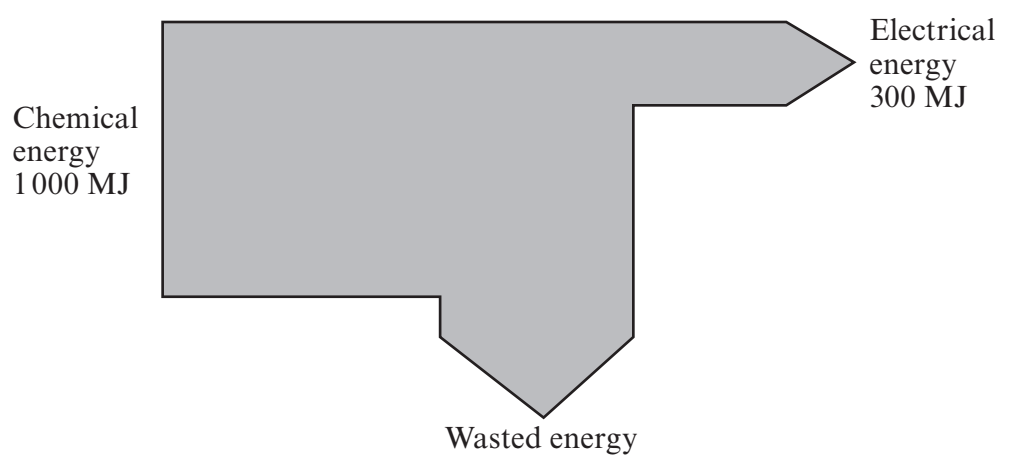

- (i) How much energy is wasted? MJ [1]
 - (ii) What happens to this wasted energy? [1]
-
- (iii) Use an equation from pages 2 and 3 to calculate the efficiency of the power station. [3]

Efficiency = %

9

2. The diagram shows a water wave on the ocean.

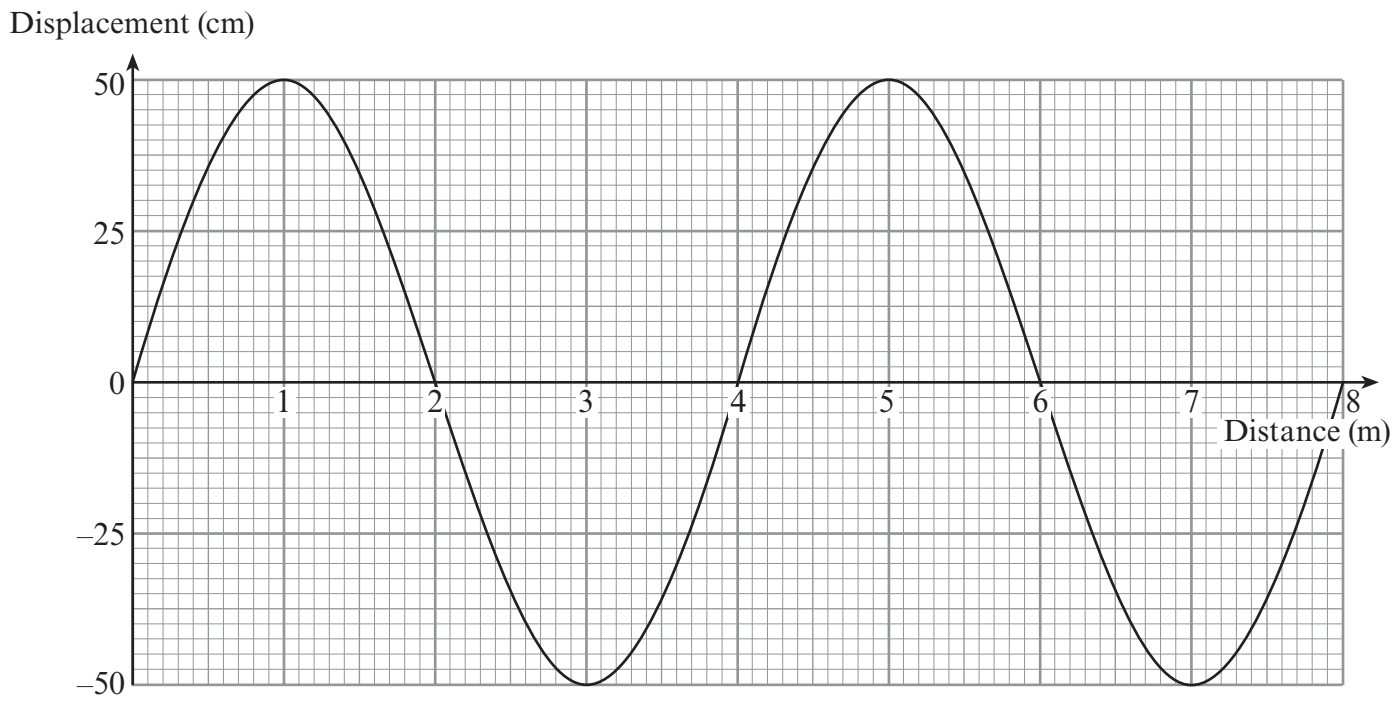

(a) (i) Write down the wavelength of the wave. m [1]

(ii) Write down the amplitude of the wave. cm [1]

(b) If the wave travels with a speed of 2.8 m/s along the surface, use the equation

$$\text{frequency} = \frac{\text{wave speed}}{\text{wavelength}}$$

to calculate the frequency of the wave. [2]

Frequency = Hz

(c) Use the equation $\text{distance} = \text{speed} \times \text{time}$

to calculate the distance travelled by the wave in 100 s. [2]

Distance = m

6

3. **Radio waves, microwaves, infra-red and visible light** are all parts of the electromagnetic spectrum that are used for communication.

(a) State **one** property that they all have in common. [1]

.....
.....

(b) State **one** way in which they are different from one another. [1]

.....
.....

(c) Use the parts of the electromagnetic spectrum named above to complete the following sentences. [3]

Information is sent along optical fibres using

Satellite dishes on Earth use to communicate with orbiting satellites.

Mobile phones receive signals.

4463
010007

5

4. The table shows data about some energy sources used to generate electricity in the UK.

Energy source	% of UK electricity generation	Total commissioning and decommissioning cost (£ million)	Generating cost per unit (p)	Output power (MW)
Coal	30	550	2.8	1 000
Gas	40	400	2.4	1 200
Nuclear	20	1 200	3.2	800
Wind turbine	0.004	2	3.3	2
Hydroelectric	3	400	3.5	80

(a) Use the information in the table to answer the following questions.

(i) Which type of energy source generates the most electricity for the UK? [1]

.....

(ii) Calculate how many wind turbines would be needed to produce the same output power as one nuclear power station. [2]

Number of wind turbines =

(iii) Apart from the total commissioning and decommissioning cost, give **two** reasons why a power company would prefer to build a gas power station rather than a hydroelectric power station. [2]

1.

.....

2.

.....

(b) Explain why the total commissioning and decommissioning cost for a nuclear power station is so high. [2]

.....

.....

.....

.....

.....

5. A householder is considering using a **renewable** energy source to help him save money on electricity bills. He used some information from a local store to draw up the following table.

	Installation cost (£)	Saving per year (£)	Payback time (years)	Maximum power output (W)	Conditions needed
Wind turbine	1 200	600	2	5 400	Average wind speed 4 m/s, (maximum 12 m/s)
Roof top photovoltaic cells (PV)	14 000	7	1 800	South-facing roof

(A photovoltaic cell (PV) converts sunlight energy into electrical energy.)

- (a) What is meant by a **renewable** energy source? [1]

.....

.....

- (b) (i) **Complete the table** by calculating the saving per year for the roof top photovoltaic cells (PV). [1]

- (ii) Give reasons why the payback times for the wind turbine **and** roof top photovoltaic cells (PV) may be different from both those shown in the table. [2]

.....

.....

.....

.....

.....

- (c) Explain how the introduction of roof top photovoltaic cells (PV) and wind turbines would benefit the environment. [2]

.....

.....

.....

.....

.....

6. A householder has bought a plug-in monitor to check the amount of energy used by different appliances.



- (a) A kettle was found to use 300 000 J of energy in 150 s. Use an equation from pages 2 and 3 to calculate the power of the kettle. [2]

Power = W

- (b) When the monitor was used with a freezer, the power was found to be 100 W. The freezer was switched on for 5 hours.

Use the equations:

$$\text{units used (kWh)} = \text{power (kW)} \times \text{time (h)}$$

$$\text{cost} = \text{units used (kWh)} \times \text{cost per unit}$$

to calculate the cost of the electricity used, if one unit costs 12 p. [4]

Cost = p

- (c) The householder can choose to pay for electricity on a Standard plan or an Economy plan.

The cost of the Standard plan for three months is shown on the grid below.

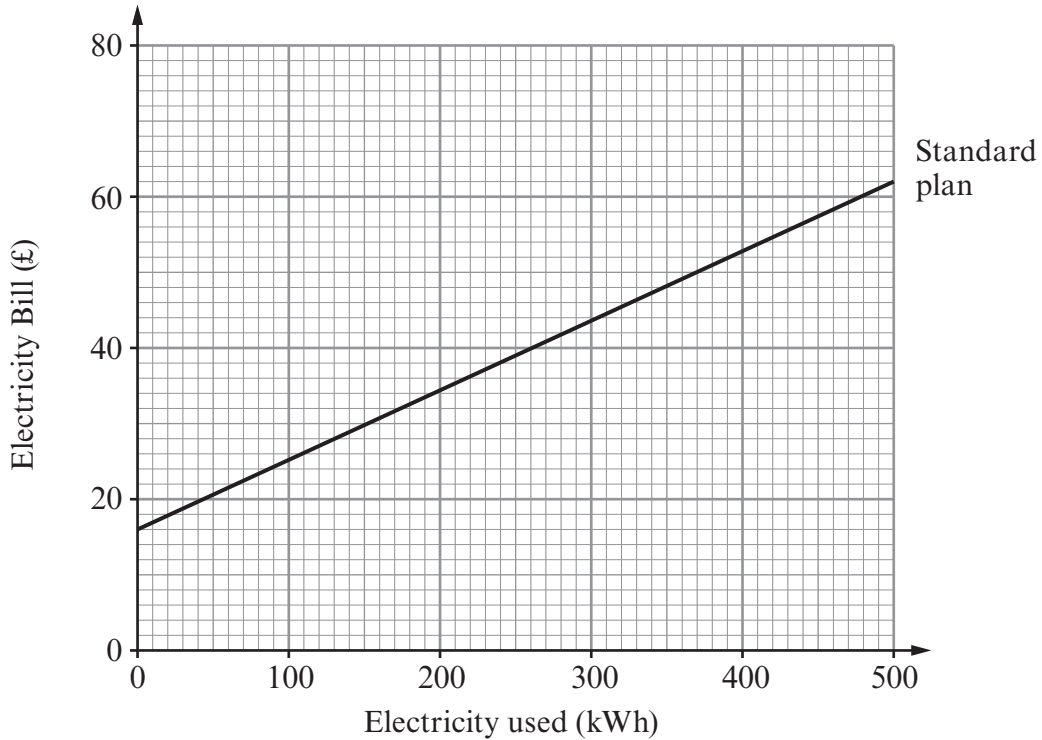

The table shows how the Economy plan cost changes with the number of kWh used during a three month period.

Number of kWh	0	100	200	300	400	500
Economy plan cost (£)	0	16	32	48	64	80

- (i) **Plot the Economy plan data** on the same grid. [3]
- (ii) Which plan would you recommend to a householder who uses 200 kWh every three months? [1]
-
- Give a reason for your answer.
- [1]
- (iii) State the minimum number of kWh a householder should use in a three month period before she decides to switch to the Standard plan. [1]

..... kWh

12

7. Cosmic microwave background radiation (CMBR) fills the entire universe. The COBE satellite measured the spectrum of the cosmic microwave background radiation in 1990. The results are shown below.

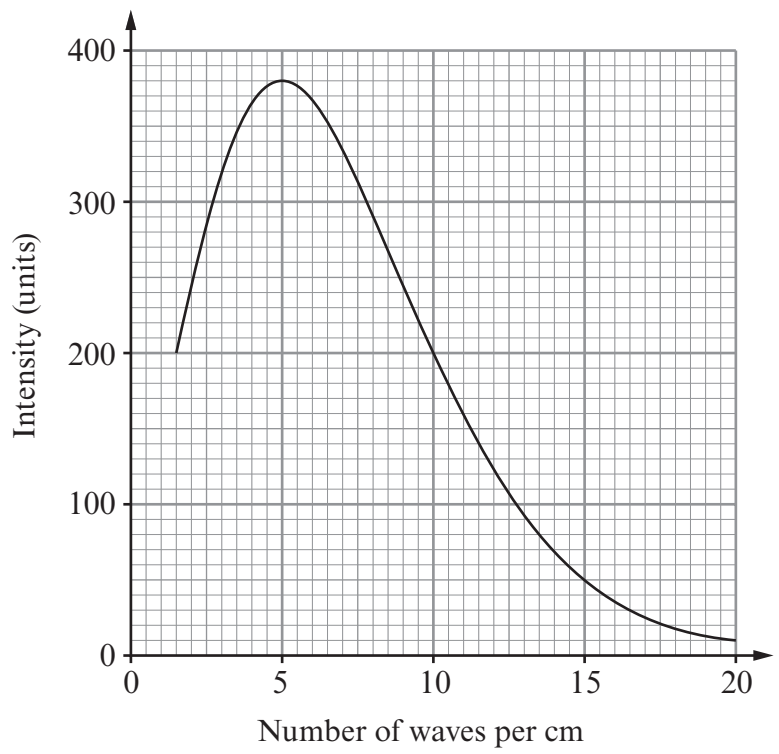

- (a) Use the graph to answer the following questions.
- (i) State the intensity of the most intense microwaves detected. units [1]
 - (ii) **Calculate** the wavelength, in millimetres, of the most intense microwaves. [2]

Wavelength = mm

- (b) The cosmic microwave background radiation (CMBR) provides evidence for the origin of the universe.
- (i) Name the theory that CMBR supports. [1]
 - (ii) Describe this theory. [2]

.....

.....

.....

.....

BLANK PAGE

Turn over for Question 8

8. A radiation detector is used to **measure the background radiation**. It shows that after 60 seconds the radiation count was 30.

It is then used to find the types of radiation that a radioactive source emits.

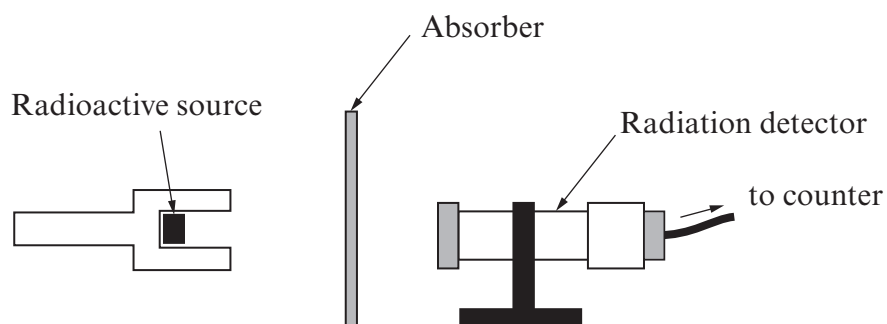

A number of different absorbers are placed, one at a time, between the detector and the radioactive source.

For each absorber, the average number of counts per second received by the detector is worked out.

The results shown in the table **include background radiation**.

Type of absorber	Average counts per second
None	25
Paper	5
Aluminium	5
Lead	2

